

ANCHORING DETAILS ARE FOR REFERENCE ONLY. FINAL SPECIFICATIONS AND DETAILS SHOULD BE APPROVED BY A LICENSED ENGINEER.

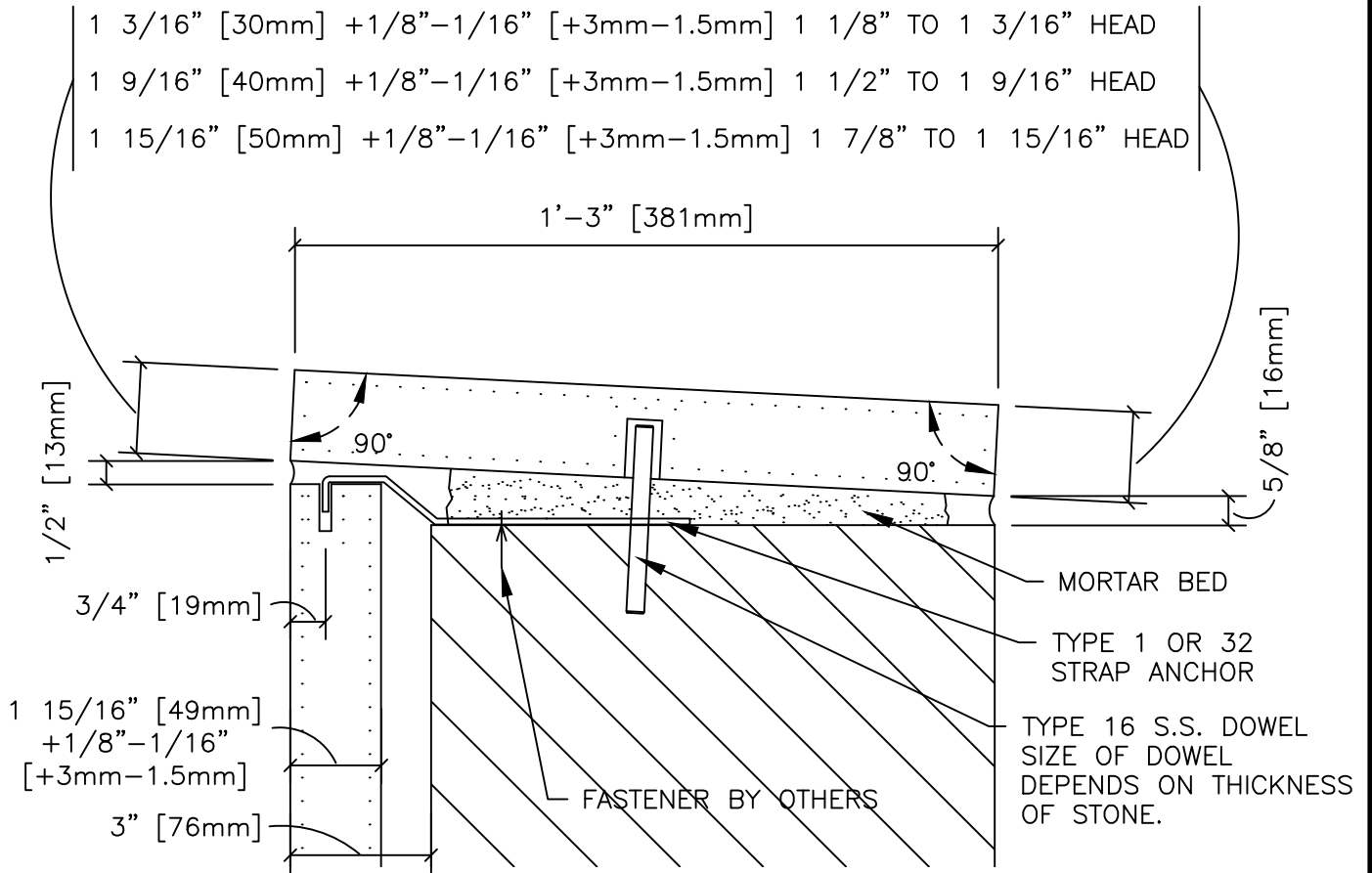

MOST ECONOMICAL

COPING WITH 90 DEGREE CORNERS – 50mm OR LESS

DESCRIPTION:

COPING WITH 90 DEGREE CORNERS  
 50mm OR LESS

SCALE:

3" = 1'-0"

DRAWN BY:

LB/KM

DATE:

8-20-13



**COLDSPRING™**

17482 GRANITE WEST ROAD, COLD SPRING, MN 56320-4578  
 PHONE (320) 685-3621, FAX (320) 685-5052  
 WWW.COLDSPRINGUSA.COM